

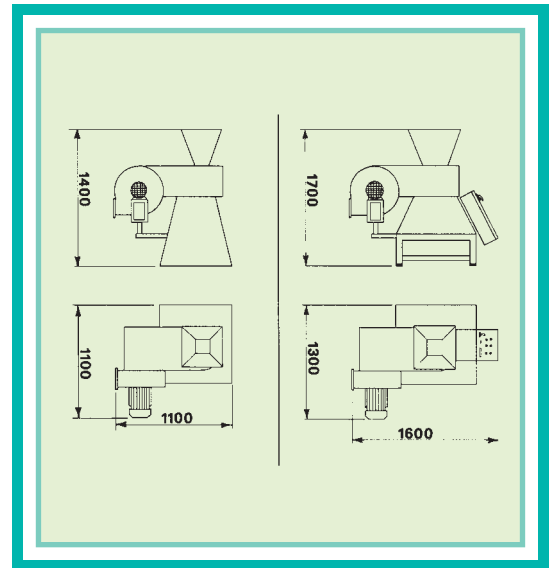



-  GRANULATORI
-  GRANULATORS
-  GRANULATEURS
-  FLOCKENMÜHLE

HP 10-20-30-40-50



-  GRANULATORI CON COCLEA
-  GRANULATORS WITH SCREW
-  GRANULATEURS À VIS
-  SCHNECKEN FLOCKENMÜHLE



- Electrical control panel
- 3 cutting knives
- 2 outfit grids of different hole size
- Suction fan from 2 HP to 4 HP
- Dimensions: see table
- Production capacity:
 GRANULATOR 10 HP 100 Kg/hour
 GRANULATOR 20 HP 150 Kg/hour
 GRANULATOR 30 HP 200 Kg/hour
 GRANULATOR 40 HP 250 Kg/hour
 GRANULATOR 50 HP 300 Kg/hour
- Safety protections



- Quadro elettrico con salvamotori
- 3 coltelli
- Ventola di aspirazione da 2 HP a 4 HP
- 2 griglie in dotazione di diverso diametro
- Dimensioni: vedi tabella
- Capacità di produzione:
 GRANULATORE 10 HP 100 Kg/ora
 GRANULATORE 20 HP 150 Kg/ora
 GRANULATORE 30 HP 200 Kg/ora
 GRANULATORE 40 HP 250 Kg/ora
 GRANULATORE 50 HP 300 Kg/ora
- Protezioni antinfortunistiche



- Tableau électrique avec protection moteurs
- 3 couteaux tranchants
- 2 grilles à trous différents e Aspirateur de 2 CV à 4 CV e Dimensions voir table
- Capacité de production:
 GRANULATEUR 10 CV 100 Kg/heure
 GRANULATEUR 20 CV 150 Kg/heure
 GRANULATEUR 30 CV 200 Kg/heure
 GRANULATEUR 40 CV 250 Kg/heure
 GRANULATEUR 50 CV 300 Kg/heure
- Protections de sécurité



- Schaltpult mit Überlastkontrolle
- 3 Schneidmesser
- 2 zusätzliche Flockensiebe nach Wohl
- Flockenabsaugung von 2 4 PS
- Raumbedarf: siehe Tabelle
- Produktionleistung:
 FLOCKENMÜHLE 10 PS 100 Kg/h
 FLOCKENMÜHLE 20 PS 150 Kg/h
 FLOCKENMÜHLE 30 PS 200 Kg/h
 FLOCKENMÜHLE 40 PS 250 Kg/h
 FLOCKENMÜHLE 50 PS 300 Kg/h
- Arbeitsschutz

